

LA COLLE

↳ PAPIER, CARTON,
TISSU ...



①

SUR FEU DOUX,
VERSER DOUCEMENT
LA FARINE & LE
SUCRE DANS L'EAU
TOUT EN MÉLANGÉANT



②
AJOUTER
UN PEU
DE
VINAIGRE

↳ SE CONSERVE QUELQUES
JOURS AU FRAIS

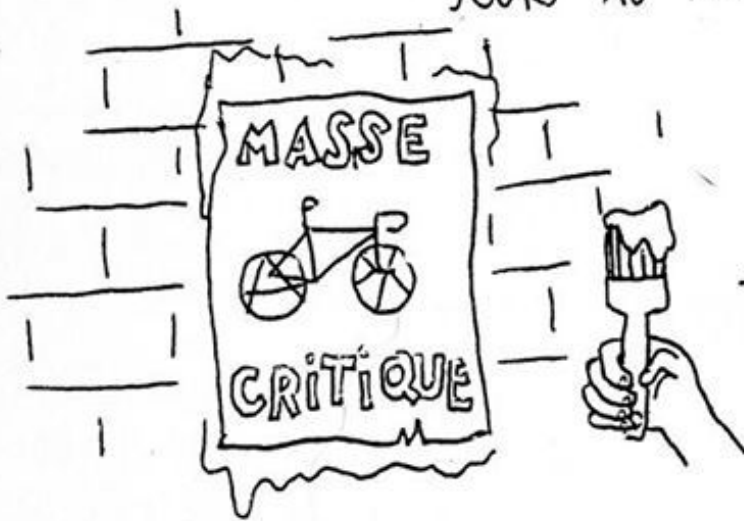

③ COLLER
DES TRUCS

LA GRAMAILLOTTE

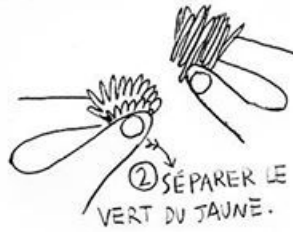
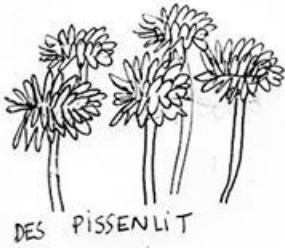

8 REMPLIR DES POTS A VIS PREALABLEMENT EBOUILLANTES. LES FAIRE REFRROIDIR A L'ENVERS. ETIQUETER



LA GRAVURE DE CUISINE

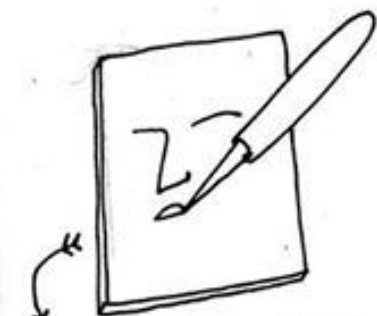
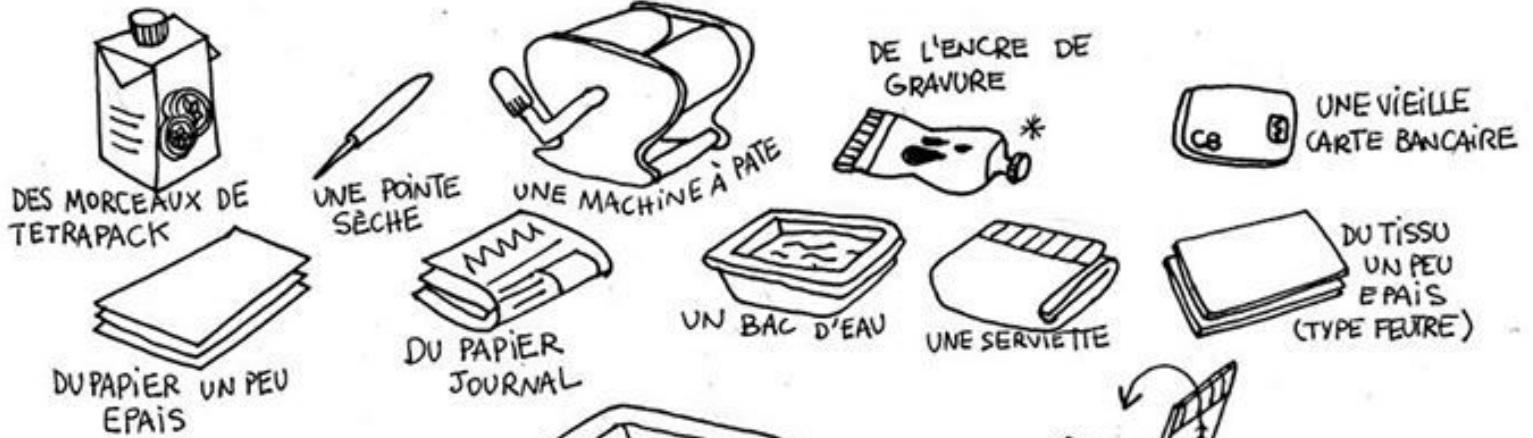

① GRAVER UNE PLAQUE DE TETRAPACK AVEC LA POINTE SÈCHE



② TREMPER LE PAPIER QUELQUES MINUTES



④ ÉTALER L'ENCRE SUR LA PLAQUE GRAVÉE



③ ESSORER DANS LA SERVIETTE

⑤ ESSUYER LE SURPLUS AVEC DU JOURNAL



⑥ IL DOIT Y AVOIR DE L'ENCRE DANS LES CREUX ET PEU SUR LA PLAQUE

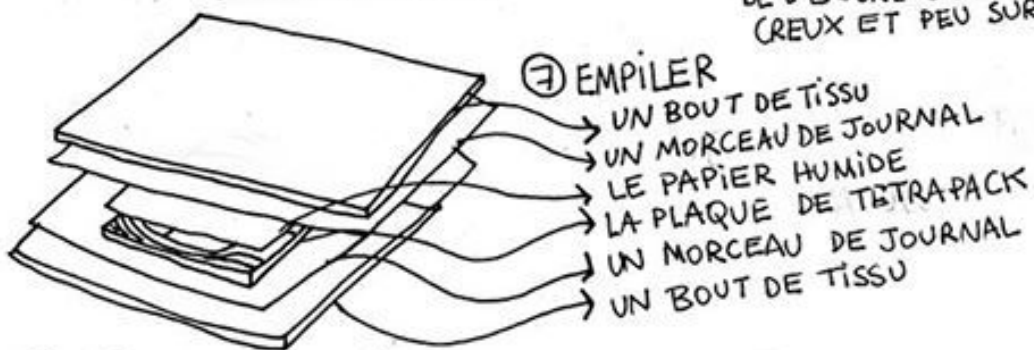

⑧ GLISSER DANS LA MACHINE À PÂTE. REGLER OU AJOUTER DU PAPIER SI BESOIN

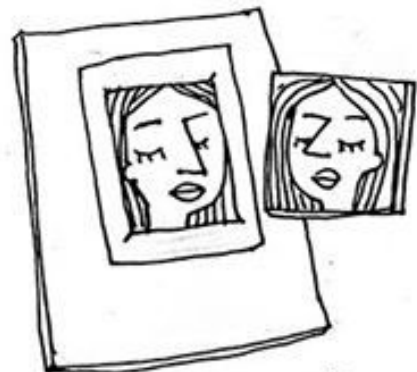

⑨ TESTER PLUSIEURS FOIS, AJUSTER, REGRAVER, CHANGER D'ENCRE OU DE PAPIER...

* DE LA GOUACHE MELANGÉE À DE LA FARINE PEUT FAIRE L'AFFAIRE...

LA RELIURE AU FIL



UN POINÇON
(UN CLOU POINTU
UNE POINTE SÈCHE...)

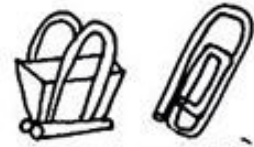

DES PINCES À
DESSIN OU DES

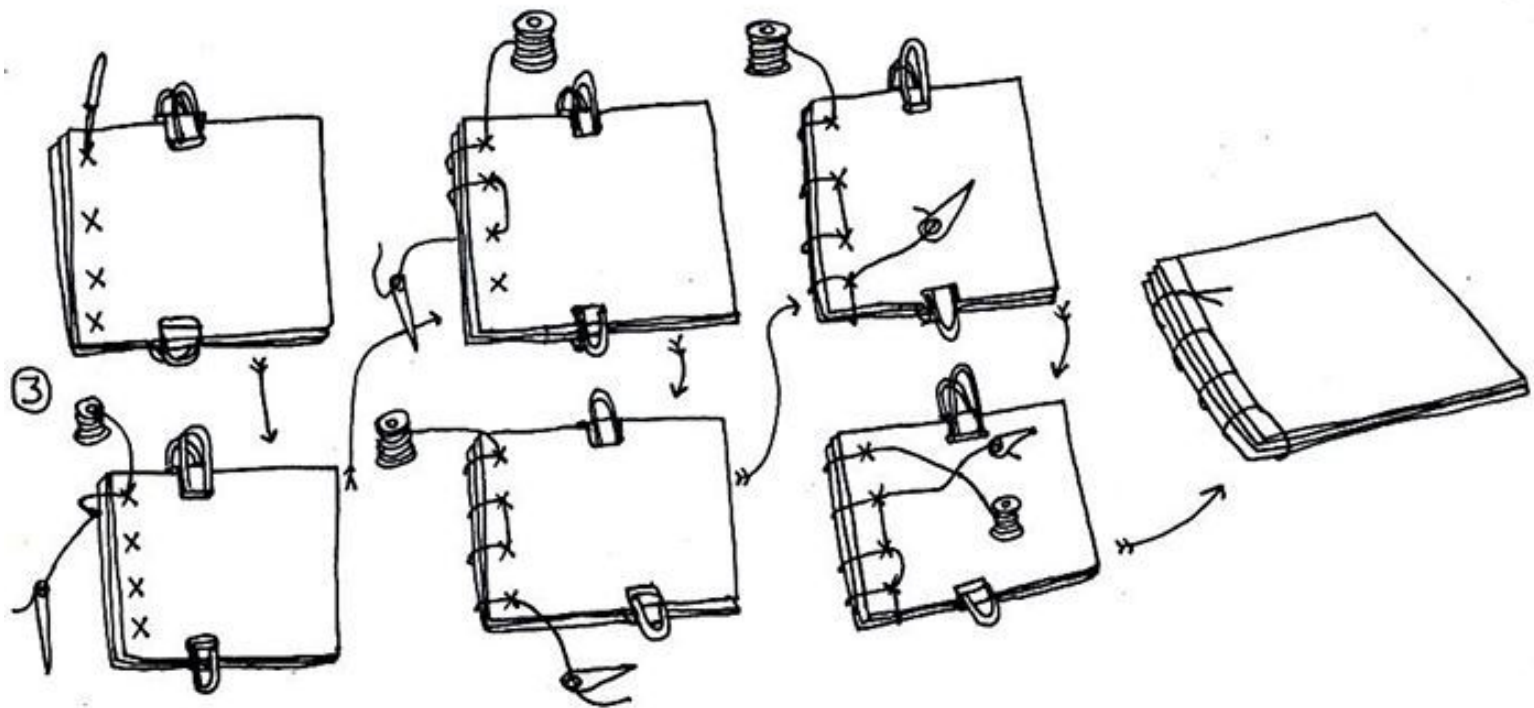
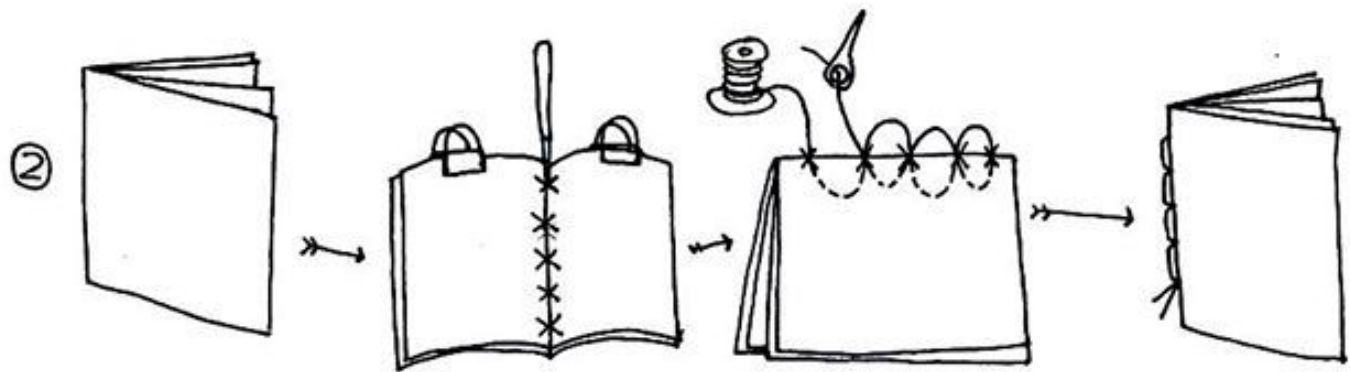
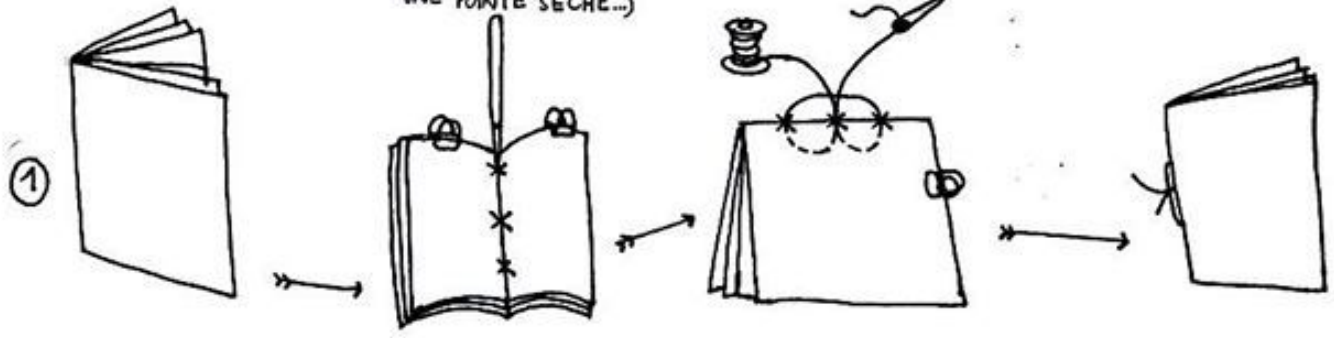

LA RELIURE FACILE

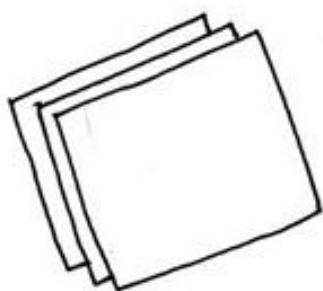

DES FEUILLES

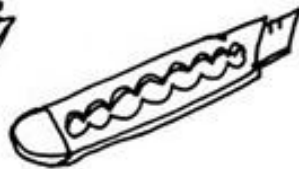
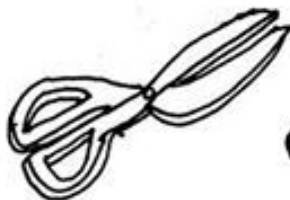

DES CISEAUX OU UN CUTTER

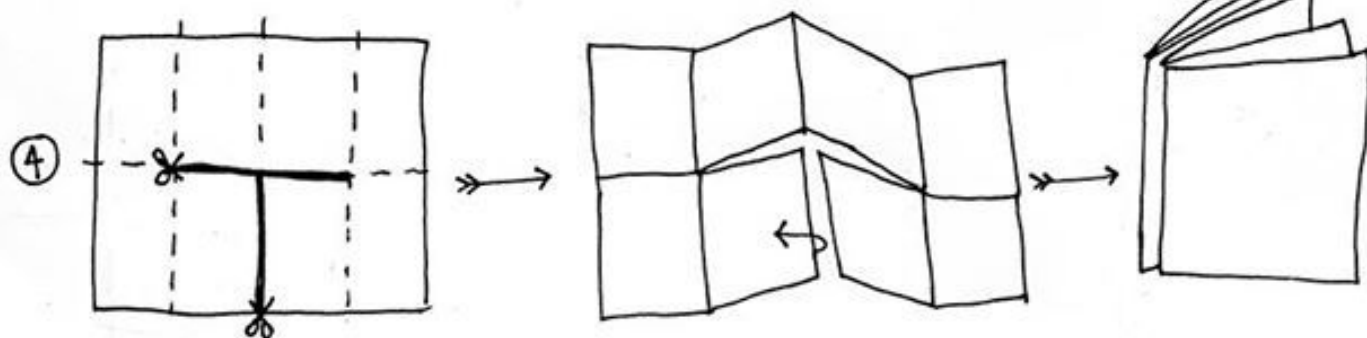
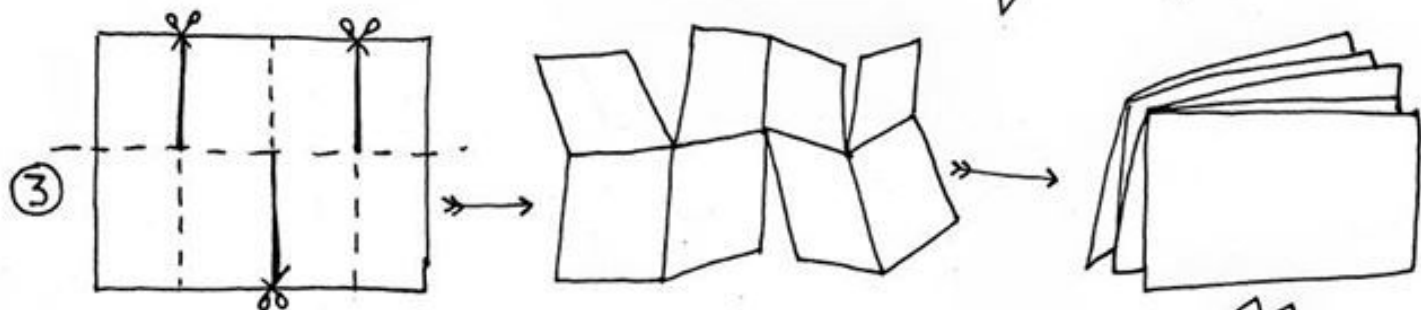
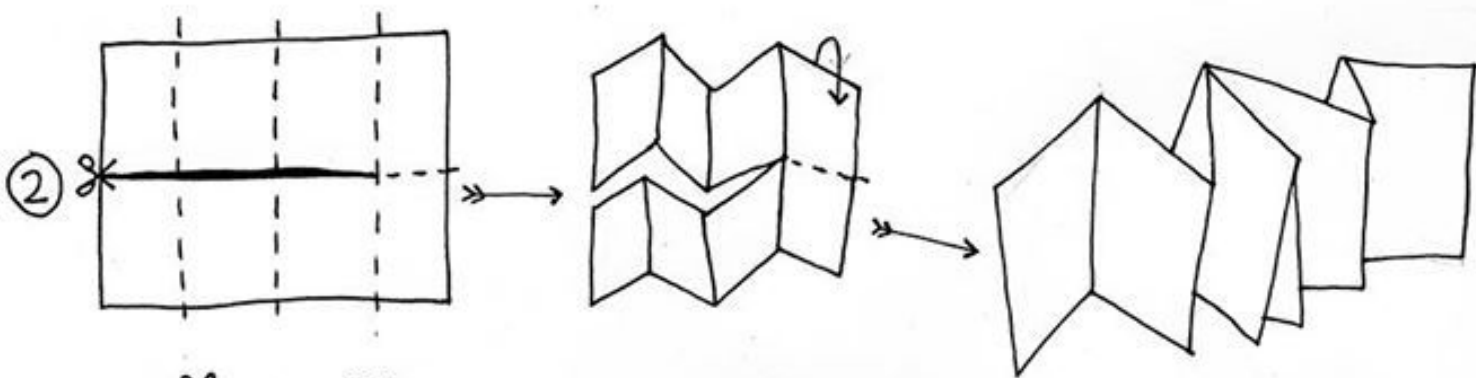
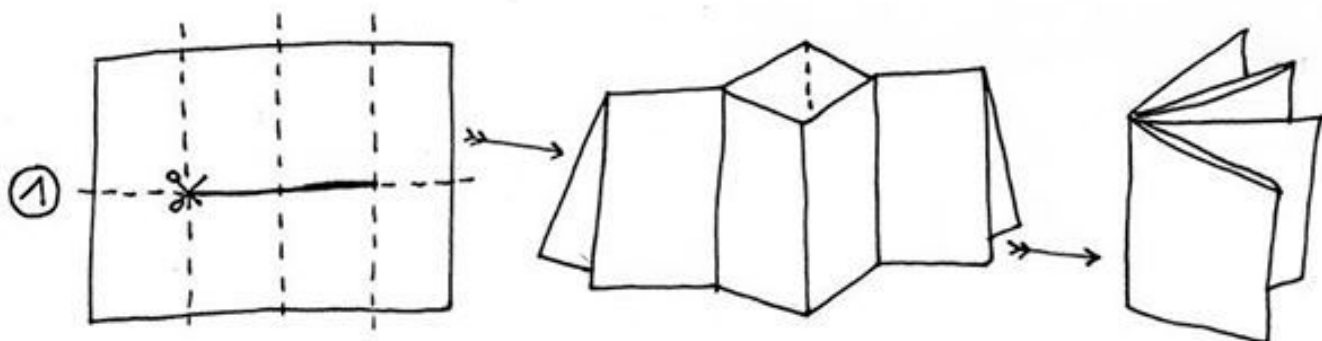

LA SERIGRAPHIE



UN CADRE ENBOIS
OU EN CARTON FORT



DES BAS NYLON
OU DU TULLE



UNE AGRAFEUSE



DE LA COLLE
LIQUIDE RESISTANTE
À L'EAU ET UN
PINCEAU



DU PAPIER



DE LA
GOUACHE



UNE VIEILLE
CARTE BANCAIRE

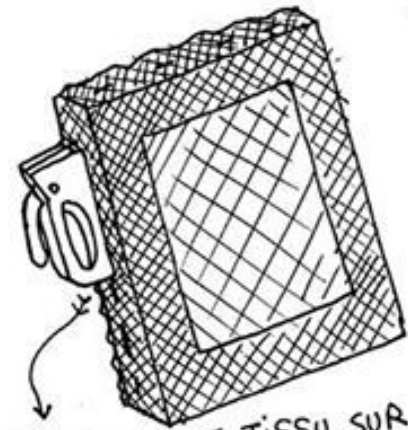

① FIXER LE TISSU SUR
LE CADRE BIEN TENDU

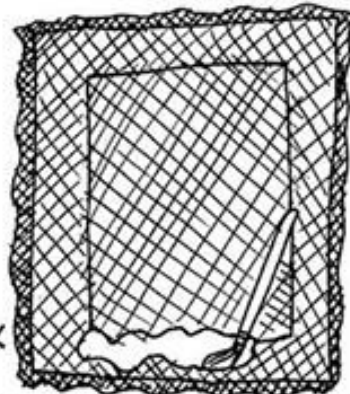

② ENDUIRE DE COLLE LÀ OÙ
LE TISSU TOUCHE LE
CADRE

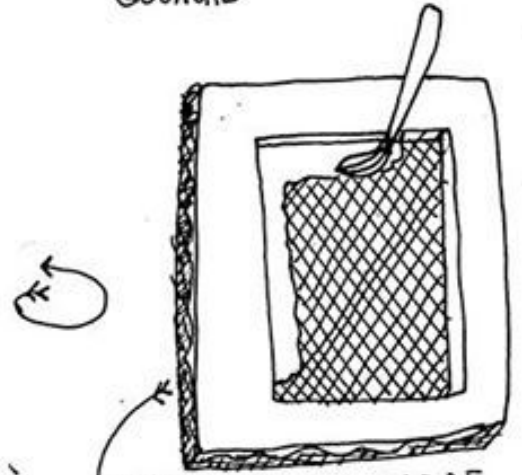

③ FAIRE UN CADRE
DE COLLE DE L'AUTRE
CÔTÉ

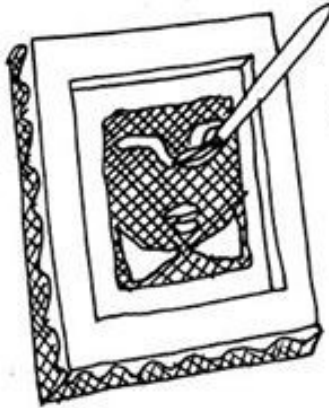

④ PEINDRE LE MOTIF À
LA COLLE. CE QUI SERA
PEINT SERA BLANC.
TÂCHER DE REMPLIR LES
TROUS SANS FAIRE
DE PÂTE.

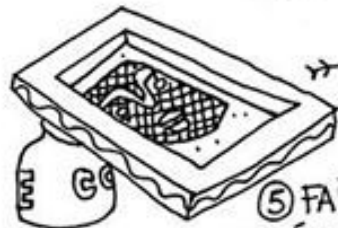

⑤ FAIRE SÈCHER
EN SURÉLEVANT.
FAIRE DES RETOUCHES SI
BESOIN.



⑥ POSER LE CADRE SUR UNE
FEUILLE ET
FAIRE UNE
LIGNE DE
GOUACHE
UNIFORME.

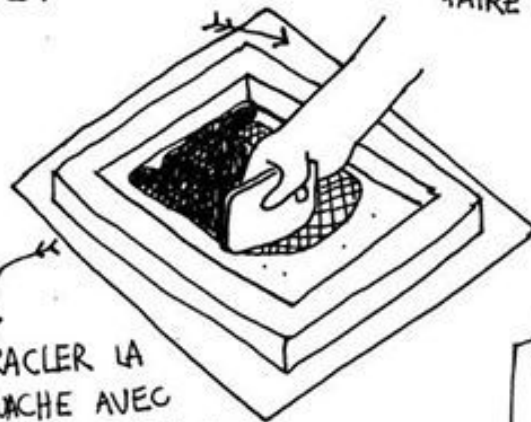

⑦ RACLER LA
GOUACHE AVEC
LA CARTE EN TENANT
LE CADRE

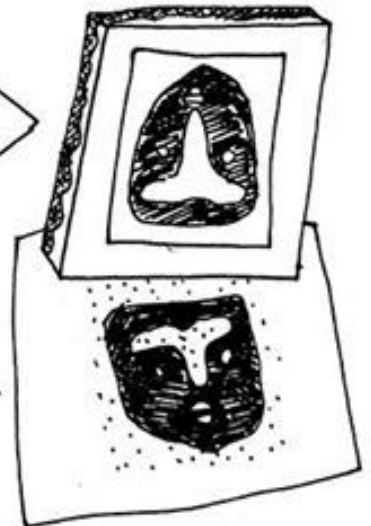

C'EST IMPRIMÉ!

L'AUTRE MONOTYPE



UNE PLAQUE LISSE
ET TRANSPARENTE



DE L'ENCRE
OU DE LA
PEINTURE



UN PINCEAU

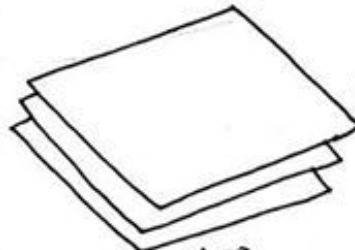

DU PAPIER

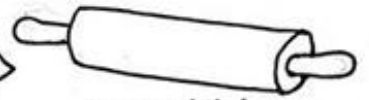

UN ROULEAU



① CHOISIR UN SUJET
(UN PAYSAGE, UNE FLEUR,
UN E AMI.E, UNE PHOTO...)



② PEINDRE SUR LA
PLAQUE (HORIZONTALE
OU VERTICALE).
GRATTER, ESSUYER,
FROTTER...

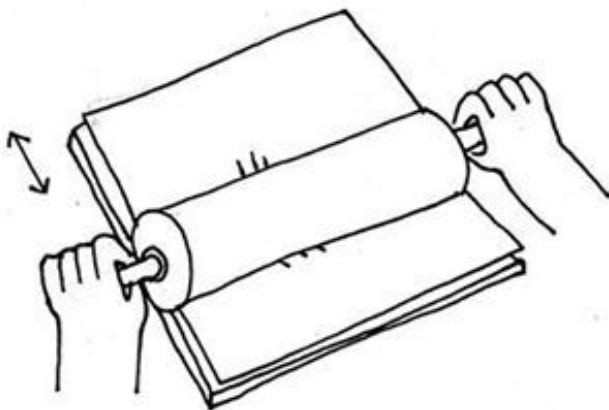

③ POSER LA PLAQUE À PLAT.
POSER UNE FEUILLE DESSUS.
ECRASER AU ROULEAU (EN TENANT
LA FEUILLE SI BESOIN)

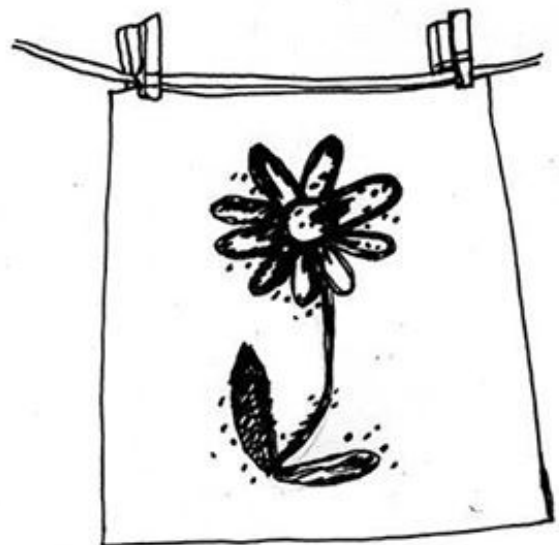

④ FAIRE SÉCHER !

LE FANZINE À MONSTRES



DES FEUILLES DE MÊME FORMAT +1



DES CISEAUX OU UN CUTTER



DES PINCES A DESSIN. OU DES PINCES A LINGE



UNE AGRAFEUSE OU DE QUOI COUDRE



DES FEUTRES, STYLOS, CRAYONS ...

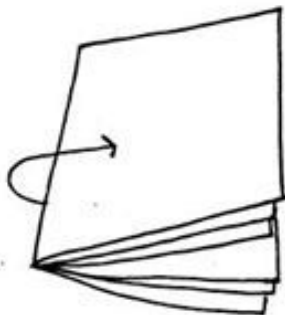

① PLIER LES FEUILLES

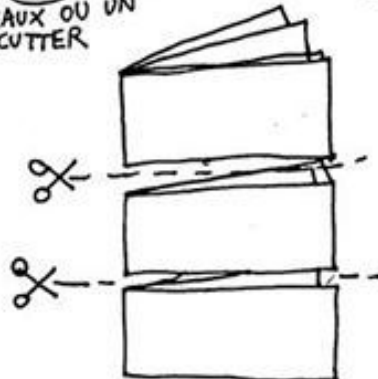

② COUPER EN TROIS PARTIES ÉGALES

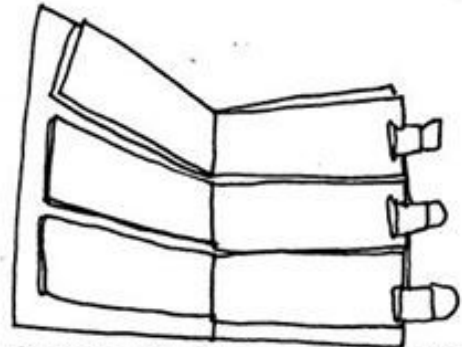

③ FIXER LES 3 "CARNETS" OUVERTS À UNE FEUILLE PLIÉE AVEC LES PINCES

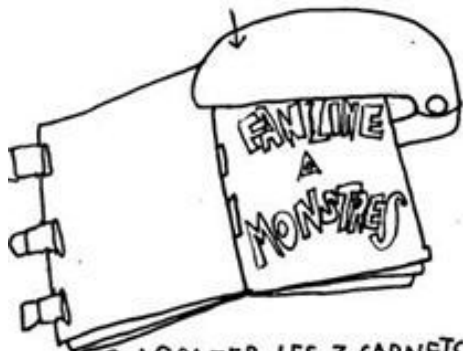

④ AGRAFER LES 3 CARNETS À LA COUVERTURE

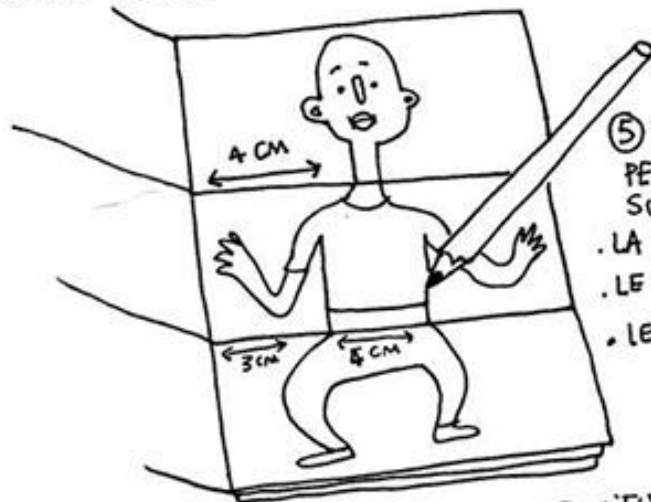

⑤ DESSINER DES PERSONNAGES SUR CHAQUE PAGE:
 • LA (OU LES) TÊTE(S)
 • LE BUSTE & LES BRAS
 • LES JAMBES.

→ POUR QUE ÇA MARCHE ENCORE MIEUX, INSTAURER UN GABARIT. PAR EXEMPLE LE COU À 4 CM DU BORD DE 2 CM DE LARGE, LE BAS DU BUSTE À 3 CM DU BORD, DE 4 CM DE LARGE ETC

→ POUR PLUS DE RIGOLADE, AJOUTER DES PHRASES AU DOS DES DESSINS :

- SUJET
- VERBE (+ COMPLÈMENT)
- COMPLÈMENT



⑥ RIGOLER!

LE GAUFRAGE

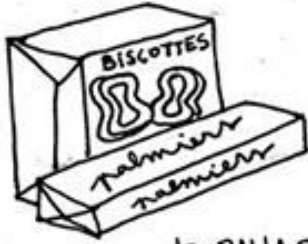

DU CARTON D'EMBALLAGE



UN CUTTER



UN BAC D'EAU & UNE
SERVIETTE EPONGE



DU PAPIER
UN FEU ÉPAIS

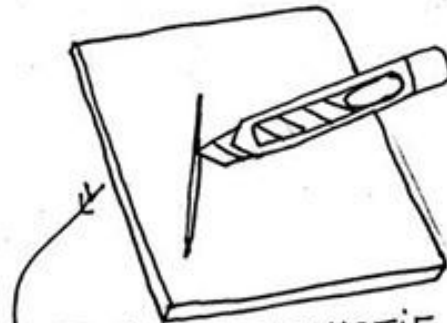
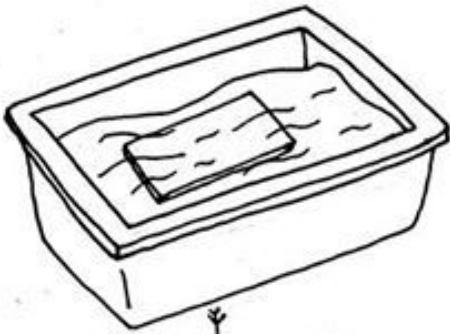

② DÉCOUPER LE MOTIF DANS LE
CARTON

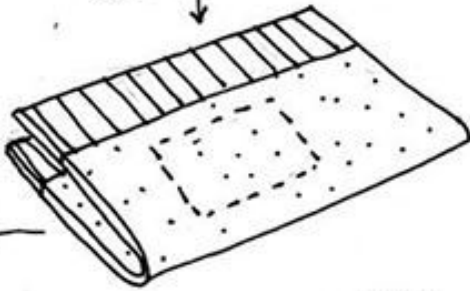

① FAIRE TREMPER LE PAPIER
& L'ÉPONGER DANS LA SERVIETTE

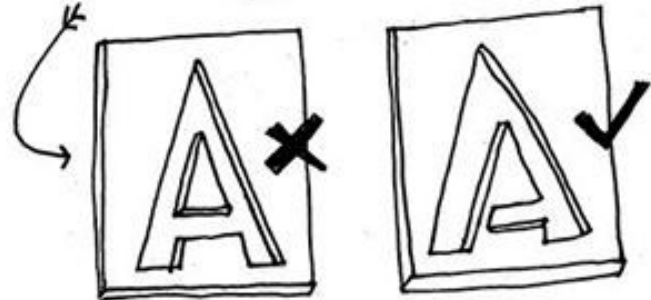

⚠ FAIRE DES LANGUETTES POUR
GARDER LES PARTIES CENTRALES

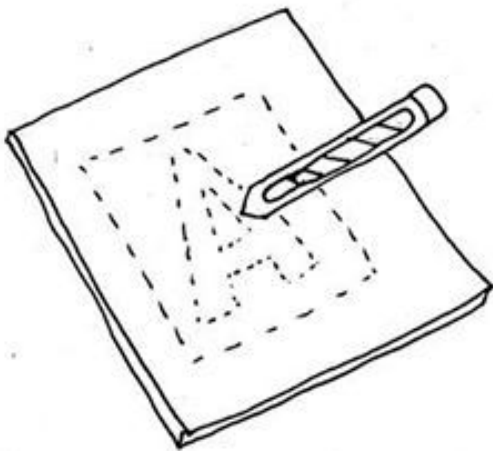

③ RETOURNER LE CARTON & Y
POSER LA FEUILLE HUMIDE.
AVEC LE CUTTER SANS LAME, FROTTER
LE PAPIER SUR TOUTE LA SURFACE

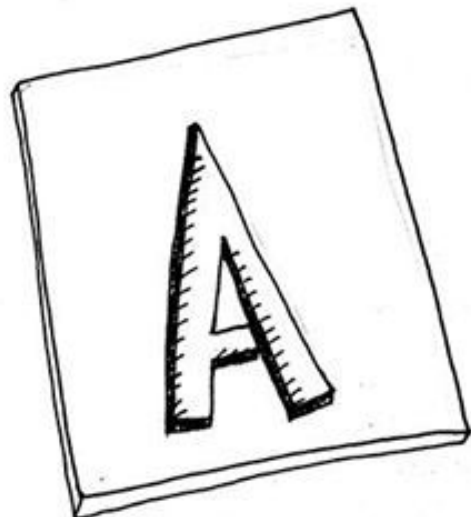

④ FAIRE SÉCHER

LE MONOTYPE



UNE PLAQUE LISSE
(VERRE, PLEXI, METAL...)



DE L'ENCRE ÉPAISSE
(ENCRE POUR GRAVURE
PEINTURE À L'HUILE
AU PIRE GOUACHE)



UN ROULEAU
(OU UN PINCEAU
OU UNE VIEILLE CB)



UN STYLO
OU UN CRAYON



DU PAPIER



DES IMAGES
À COPIER



① ETALER L'ENCRE UNIFORMÉMENT
SUR LA PLAQUE



② POSER DÉLICATEMENT
UNE FEUILLE ET L'IMAGE À REPRODUIRE
(FIXÉE ENSEMBLE SI BESOIN)



③ DESSINER ET FAIRE
ATTENTION À NE PAS POSER
LA MAIN SUR LA FEUILLE.



④ DÉCOLLER DOUCEMENT LA
FEUILLE. LE DESSIN S'Y EST
IMPRIMÉ !

⑤ NETTOYER À L'HUILE OU À L'EAU SELON L'ENCRE.

LE PAPIER CARBONNE



DES CRAIES GRASSES
OU DES CRAYONS DE
COULEURS

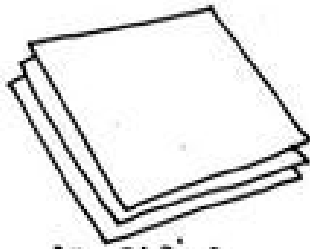

DU PAPIER

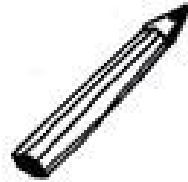

UN CRAYON OU
UN STYLO À POINTE
FINE

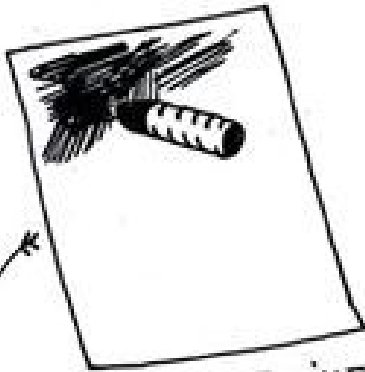

① RECOUVRIR UNE FEUILLE
DE COULEUR(S)

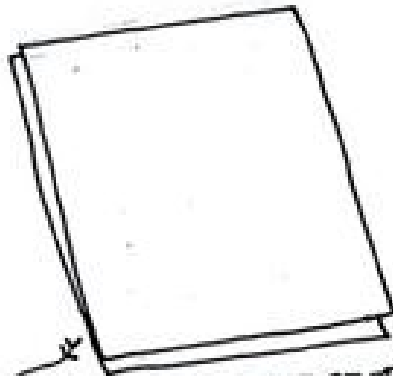

② RETOURNER CETTE FEUILLE
SUR UNE AUTRE



③ FAIRE UN DESSIN
EN MAINTENANT LES
FEUILLES ENSEMBLE

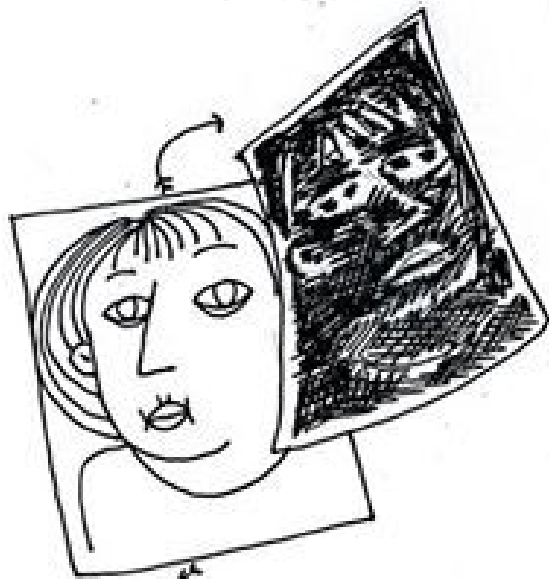

④ RETIRER LE "PAPIER
CARBONNE"

LE PAPIER RECYCLE

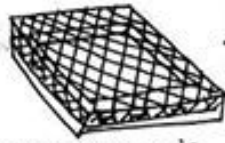

UN CADRE EN BOIS
AVEC UN TISSU MAILLÉ
TENDU DESSUS

(BAS NYLON, TARIATANE,
TULLE, MOUSTIQUAIRE...)



DU PAPIER
EN PETIT
MORCEAU



DE
L'EAU



UN MIXER
(OU UN FOUET
ET DES BISCOTES)



UN BAC
D'EAU UN PEU
PROFOND



UNE ÉPONGE

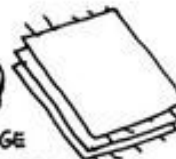

DES BOUTS
DE COTON (DE
LA TAILLE DU
CADRE)



DES SERVIETTES
ÉPONGES

1 FAIRE
TREMPER LE
PAPIER ET
L'EAU PUIS
MIXER LONGTEMPS



2 JETER UNE POIGNÉE
DE PÂTE DANS
L'EAU LE
BAC



3 TOUILLER
AVEC LA MAIN



4 PLONGER LE CADRE DANS L'EAU



5 SECOUER DANS TOUS LES
SENS MAIS DOUCEMENT

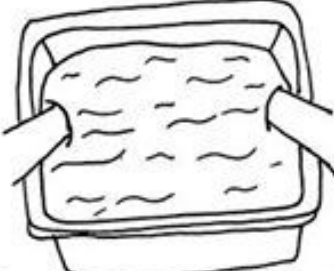

6 SORTIR LE CADRE TOUT EN
CONTINUANT À SECOUER.
LAISSER ÉGOUTTER 5MN

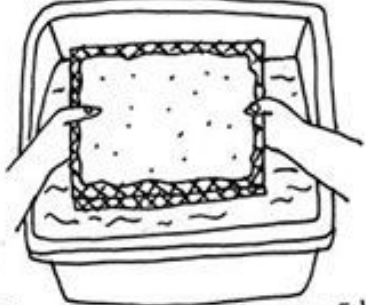

7 RENSERVER LE CADRE SUR
UN TISSU POSÉ SUR UNE
SERVIETTE.



8 ÉPONGER

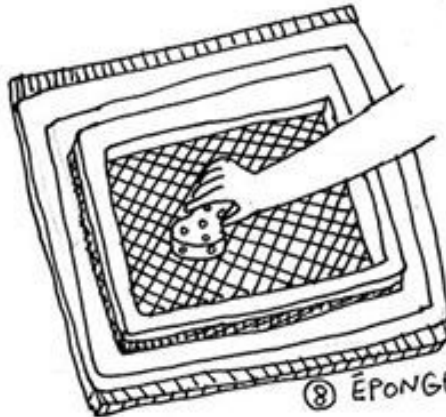

9 DÉCOLLER LE CADRE
DÉLICATEMENT

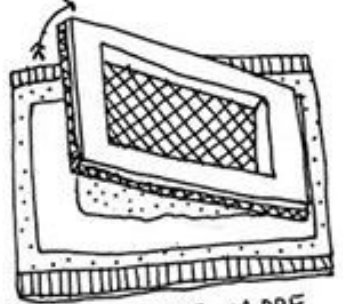

10 POSER UN TISSU +
UNE SERVIETTE
ET FAIRE SÉCHER
SOUS UN POIDS



11 DESSINER,
PEINDRE,
S'AMUSER...



LE POCHOIR

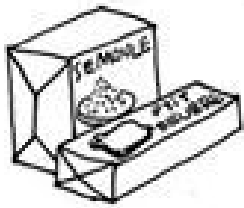

DU CARTON OU
DU PLEXI FIN
(DE VIEILLES RADIOS)

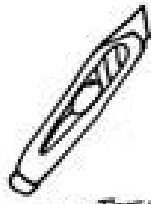

UN CUTTER



UN FEUTRE



DE LA
PEINTURE

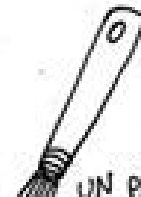

UN PINCEAU,
UN BOUT
D'ÉPONGE, DES
DOIGTS...

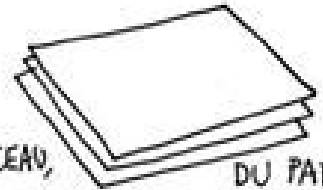

DU PAPIER
OU AUTRES
SUPPORTS



① DESSINER UN MOTIF
SUR LE CARTON

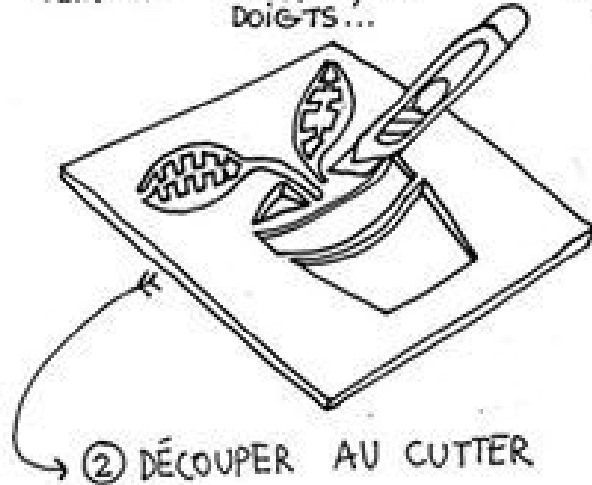

② DÉCOUPER AU CUTTER

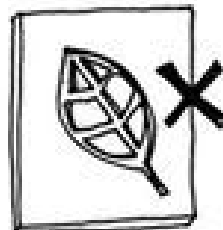

⚠ LAISSER DES LANGUETTES POUR
CONSERVER LES PARTIES CENTRALES.
RÉPARER AU PAPIER COLLANT SI BESOIN

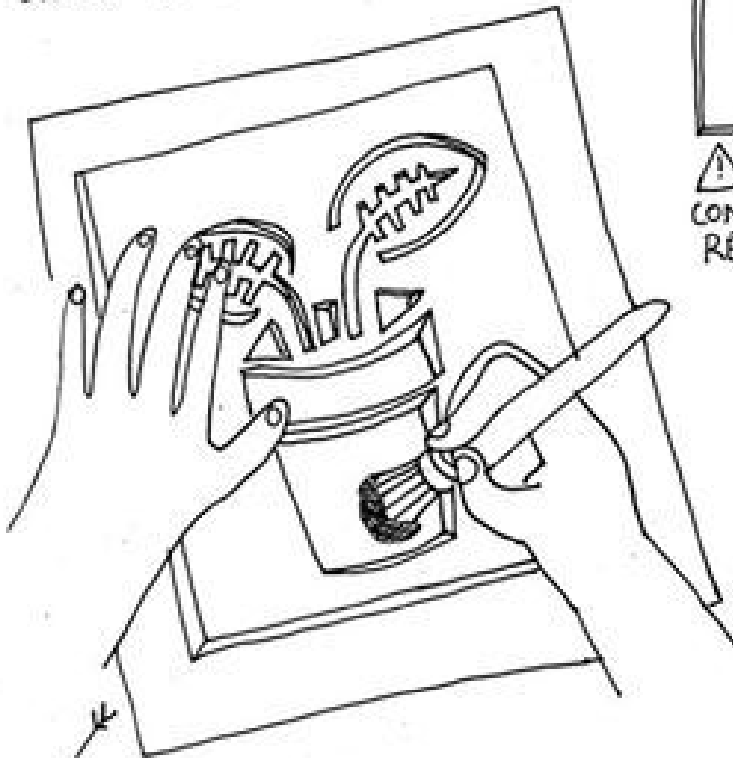

③ POSER LE POCHOIR SUR LE SUPPORT
PUIS TAMPONNER AVEC UN PINCEAU
TREMPÉ DANS LA PEINTURE

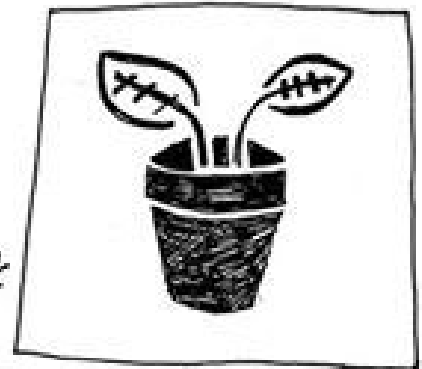

④ FAIRE SÉCHER
ET RECOMMENCER!

LES TAMPONS

UN TAMPON ENCREUR
(DU TISSU OU UNE EPONGE IMBIBÉE D'ENCRE)

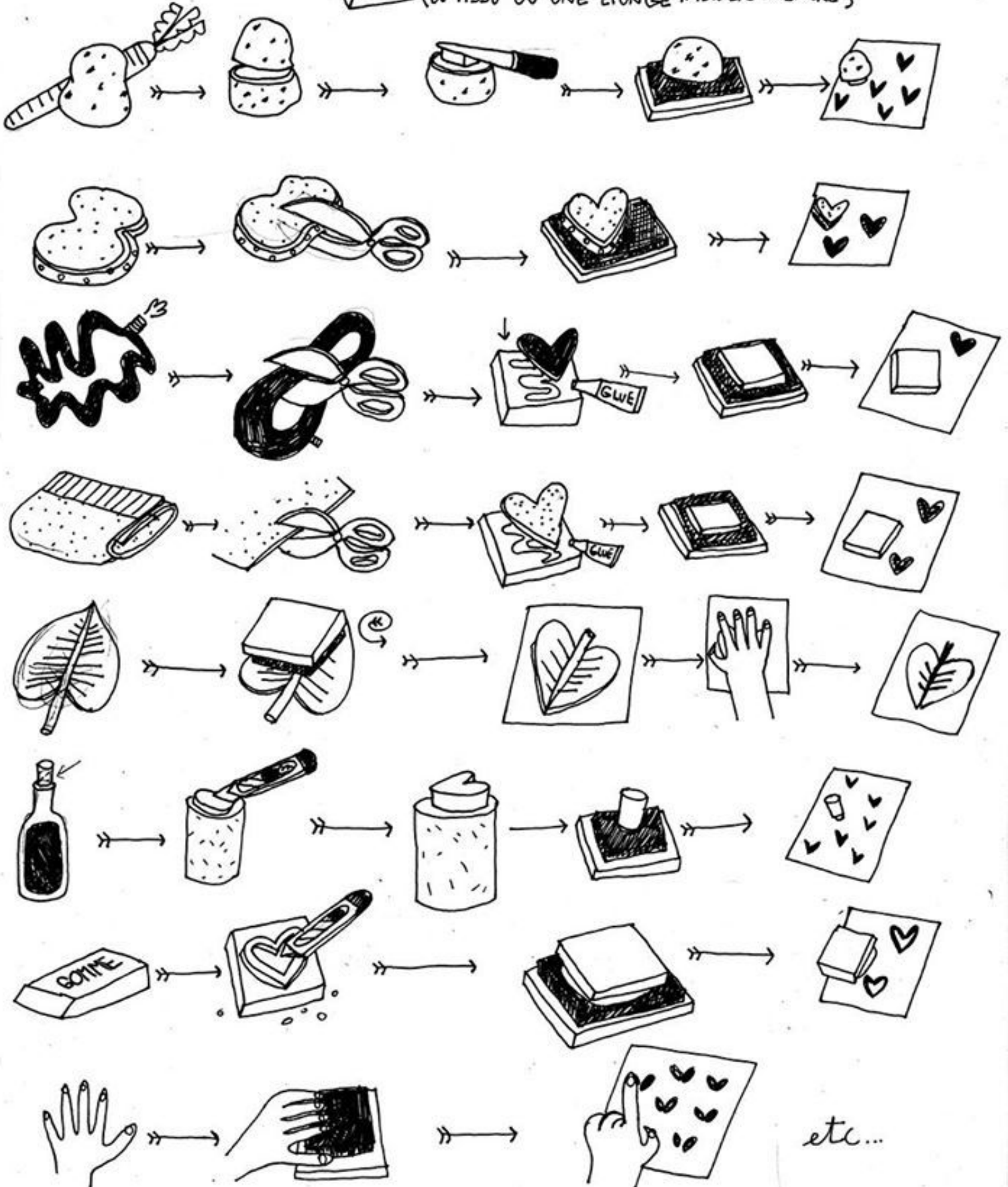

L'IMPRESSI^xON À LA CUI^xLLÈRE

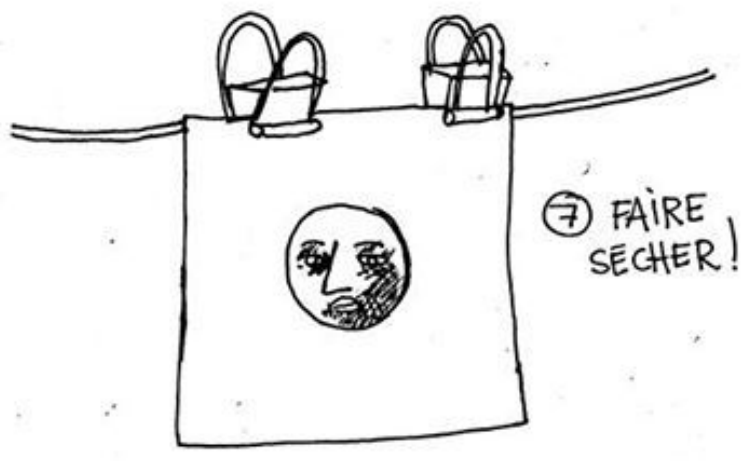
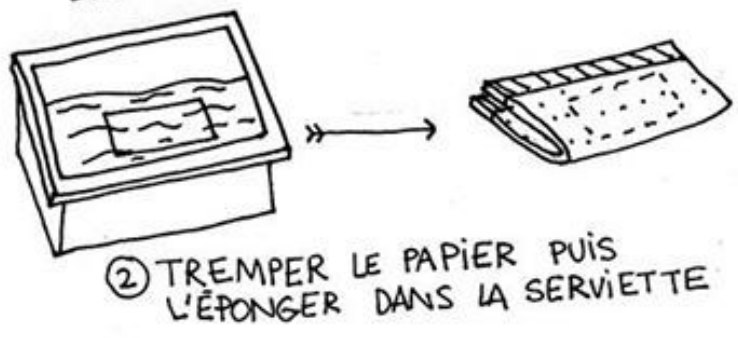

L'IMPRESSSION CARTON

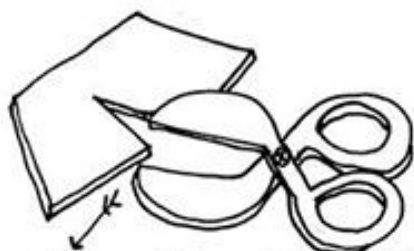

① COUPER DES MORCEAUX DE CARTON



② COLLER SUR UNE PLAQUE DE CARTON POUR FORMER UNE IMAGE EN RELIEF

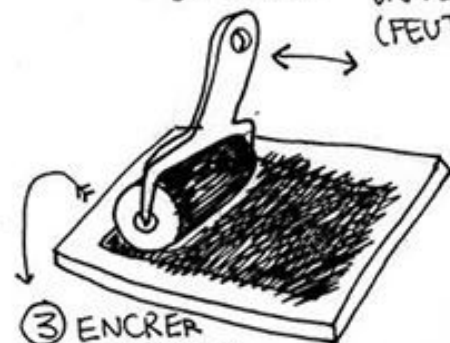

③ ENCRER LE ROULEAU EN ÉTALANT L'ENCRE SUR LA PLAQUE LISSE

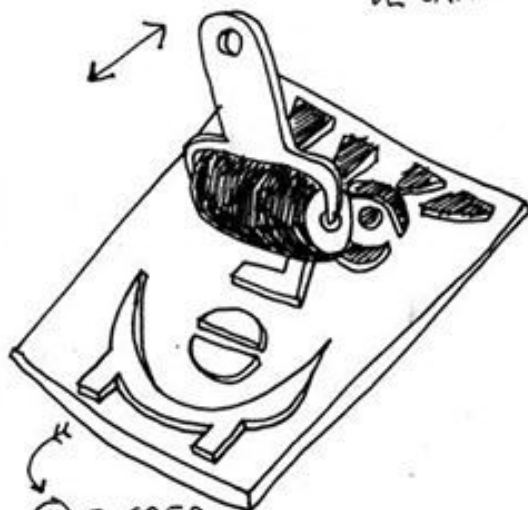

④ ENCRER LA MATRICE

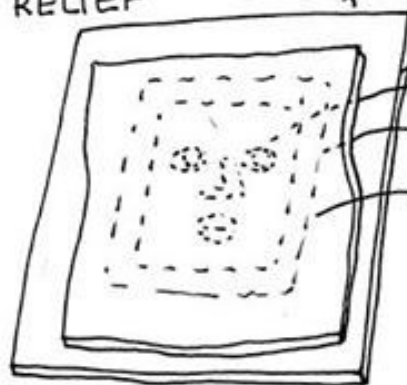

⑤ EMPILER SUR UNE SURFACE PLANE LA PLAQUE ENCRÉE, UNE FEUILLE VIERGE ET LE TISSU.



⑦ FAIRE SÉCHER LES IMPRESSIONS ET ESSAYER AVEC D'AUTRES MATIÈRES: TISSU, PLASTIQUE, POLYSTYRÈNE, MOUSSE, CHAMBRE À AIR, DENTELLE, FEUILLES D'ARBRE ...



⑥ PASSER LE ROULEAU À PATISSERIE EN APPUYANT FORT